



Deploying the BIG-IP System v11 with SAP NetWeaver and Enterprise SOA: Portal

What's inside:

- 2 Prerequisites and configuration notes
- 3 Configuration example
- 4 Configuring the SAP Enterprise Portal for load balancing
- 7 Preparation Worksheet
- 8 Configuring the BIG-IP iApp for SAP Enterprise Portal
- 12 Next steps
- 14 Appendix: Manual configuration table

Welcome to the F5 deployment guide for SAP® NetWeaver® and Enterprise SOA: Enterprise Portal. This document provides guidance on how to configure the BIG-IP system v11 with SAP Enterprise Portal deployments.

BIG-IP version 11.0 introduces iApp™ Application templates, an extremely easy and accurate way to configure the BIG-IP system for SAP Enterprise Portal.

Why F5?

F5 technology provides an adaptable and agile network framework for SAP deployments. This allows organizations to ensure quality of service and manageability, apply business policies and rules to content delivery, support increasing traffic volumes, deliver applications securely, enjoy operational efficiency and cost control, and remain flexible to future application and infrastructure changes. The result is elegant and powerful solutions to protect you from security threats, network failures and traffic congestion, while providing an optimized architecture for the future.

To provide feedback on this deployment guide or other F5 solution documents, contact us at solutionsfeedback@f5.com.

Products and versions tested

Product	Version
BIG-IP LTM	v11
SAP NetWeaver and Enterprise SOA	SAP ERP 6.0, mySAP ERP 2005

Important: Make sure you are using the most recent version of this deployment guide, available at <http://www.f5.com/pdf/deployment-guides/sap-portal-iapp-dg.pdf>.

What is F5 iApp™?

New to BIG-IP version 11, F5 iApp is a powerful new set of features in the BIG-IP system that provides a new way to architect application delivery in the data center, and it includes a holistic, application-centric view of how applications are managed and delivered inside, outside, and beyond the data center. The iApp template for SAP acts as the single-point interface for building, managing, and monitoring SAP Enterprise Portal deployments.

For more information on iApp, see the *F5 iApp: Moving Application Delivery Beyond the Network* White Paper: <http://www.f5.com/pdf/white-papers/f5-iapp-wp.pdf>.

Document Version

1.0

Prerequisites and configuration notes

The following are general prerequisites and configuration notes for this guide:

- We recommend using the latest version of SAP NetWeaver and mySAP Business Suite applications. Our testing environment included both SAP ERP 6.0 based on NetWeaver 7.0 and SAP NetWeaver 2004 and mySAP ERP 2005. High availability was configured for Enterprise Portal and Composite Services on the front end along with Exchange Infrastructure (XI) now renamed to Process Integration (PI), Business Warehouse (BW), and SAP ERP Central Component (ECC).
- There are important changes required for the SAP Portal configuration, see *Configuring the SAP Enterprise Portal for load balancing on page 4*.
- This document is written with the assumption that you are familiar with both F5 devices and SAP products. For more information on configuring these devices, consult the appropriate documentation.
- For this deployment guide, the BIG-IP LTM system **must** be running version 11.0 or later. If you are using a previous version of the BIG-IP LTM system, see the Deployment Guide index on F5.com. The configuration described in this guide does not apply to previous versions.
- This document provides guidance for using the iApp for SAP Enterprise Portal found in version 11.0 and later. For advanced users extremely familiar with the BIG-IP, there is a manual configuration table at the end of this guide. However, we strongly recommend using the iApp template.
- If you are using the BIG-IP system to offload SSL, we assume you have already obtained an SSL certificate and key, and it is installed on the BIG-IP LTM system. When you configure the iApp, you are asked for the SSL Certificate and Key you imported for SAP.
- This guide contains guidance for SAP Enterprise Portal. For the SAP ERP Central Component iApp deployment guide, see <http://www.f5.com/pdf/deployment-guides/sap-ecc-iapp-dg.pdf>.
- This deployment guide contains guidance on optional modules, including Application Visibility Reporting, WebAccelerator, and Application Security Manager (ASM). To take advantage of these modules, they must be licensed and provisioned before starting the iApp template. For more information on licensing modules, contact your sales representative. Note that AVR is licensed on all systems, but must be provisioned before beginning the iApp template.

Configuration example

The following traffic flow diagram shows the configuration described in this deployment guide.

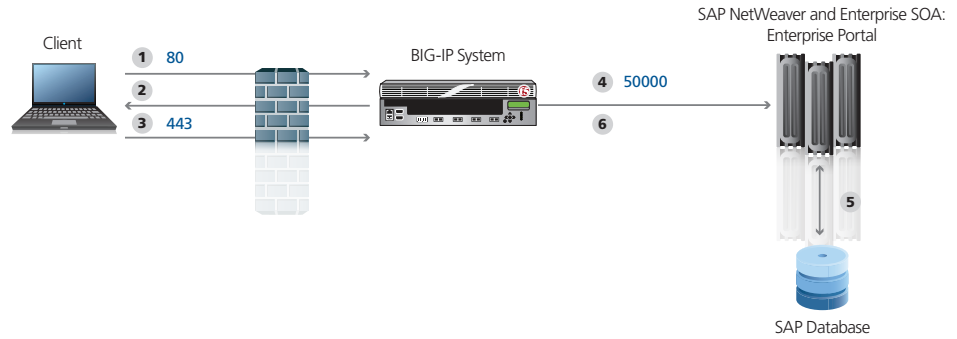

Figure 1: Configuration example

Traffic Flow:

1. The client makes a connection to the virtual server IP Address for the SAP Enterprise Portal servers residing on the BIG-IP.
2. Depending on the configuration, the BIG-IP may use an iRule to redirect the client to an encrypted (HTTPS) form of the resource.
3. The client machines makes a new connection to the BIG-IP virtual server IP address of the SAP Enterprise Portal server to access the resource over an encrypted connection.
4. The BIG-IP LTM chooses the best available Enterprise Portal device based on the load balancing algorithm and health monitoring.
5. The SAP application interacts with the SAP database.
6. The BIG-IP uses persistence to make sure the clients persist to the same server if applicable.

Configuring the SAP Enterprise Portal for load balancing

This section contains a brief description of how to create a new **System** within SAP EP using the load balancing template that allows the BIG-IP LTM system to load balance the SAP devices.

Important



This is only an overview of some of the SAP configuration details related to load balancing. For more details on configuring your SAP solution, see the SAP documentation or contact SAP.

Creating a SAP System

Use the following procedure to create a new SAP System.

To create a system

1. Log on to the SAP Enterprise Portal (EP).
2. On the Menu bar, click **System Administration**, and then click **System Configuration**.
3. In the Detailed Navigation pane, click **System Landscape**.
4. Expand **Portal Content**, and then the name of your company/portal.
5. Right click **Systems**. From the Systems menu, select **New**, and then **System (from template)**. The System Wizard opens.

You create a new System for each non EP SAP application type.

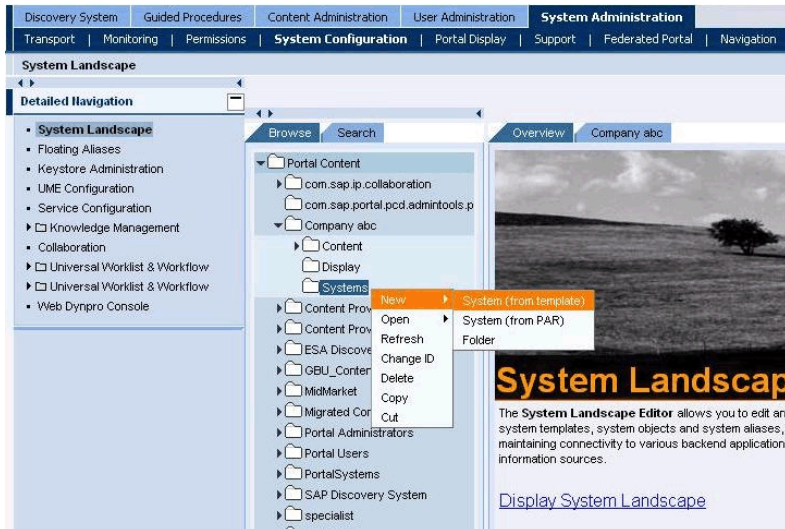

6. From the System Wizard, Template Selection, select **SAP system with load balancing** (you may need to scroll down to see this option depending on your installation).
7. Click the **Next** button.
8. In the General Properties step, enter the following information:
 - a. In the **System Name** box, type a name for this system, using the following syntax:
SAP <System Type> <System Name> In our example, we type **SAP ECC**.
 - b. In the **System ID** box, type a system ID, using the following syntax: **sap_<system id>**
In our example, we type **sap_ecc**.

- c. In the **System ID Prefix** box, type a system ID using a prefix from the SAP deployment guidelines: **com.<companyname>.erp.ops.sys**.
In our example, we type **com.companyabc.erp.ops.sys**.
- d. From the **Master Language** list, select a language. In our example, we select **English**.
- e. In the **Description** box, you can type an optional description of this system.

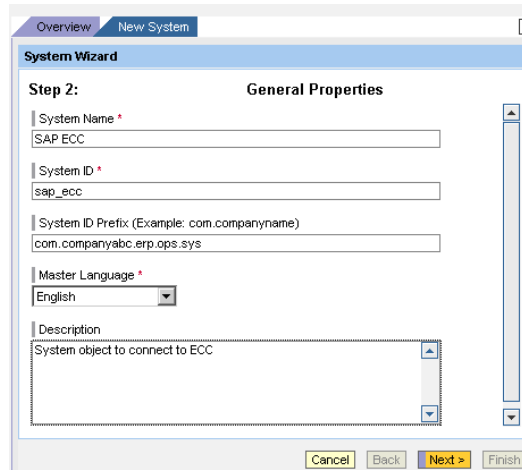

- 9. Click the **Next** button.
- 10. Review the Summary screen. To accept your entries, click **Finish**.
- 11. In the **Choose your next step** menu, select **Open object for editing** and then click **OK**.
- 12. Complete the Property Editor based on the following table.

Property	Value	Example
Group	<Group ID>	ECC_PRD_01
ITS Host Name	<Load-balanced ITS server host name>:80<System #>	Gerp.ecc.site.com:8050 *see warning
ITS Path	<Path to ITS home>	/sap/bc/gui/sap/its/
ITS Protocol	"http" or "https"	http
Logical System Name	<System ID>CLNT<System #>	RP1CLNT030
Message Server	<System message server>	usri-pdbx-c01.site.com
SAP Client (*)	<SAP Client>	030
SAP System ID	<System ID>	RP1
Server Port	36<System #>	3650
System Type	<Type of system>	SAP_R3
WAS Host Name	<Load-balanced WAS server host name>:5<System #>00	gerp-rp1-ecc.site.com:55000 *see warning
WAS Path	<WAS path>	/webdynpro/dispatcher
WAS Protocol	"http" or "https"	http

Critical



** In the preceding examples, some entries include port numbers. It is critical that **if you are using the BIG-IP LTM system to terminate SSL traffic, you do NOT use port numbers as shown in the table**. If application ports are hardcoded, SSL termination breaks the application.*

13. From the **Display selection** box, click **System Aliases**. The System Alias Editor opens.
14. In the **Alias** box, type at least one system alias for each object. Every object should have a system alias of the form **SAP_<System Type>_<Environment>** (for example **SAP_SRM_QAS**).

Note that certain system aliases are required for the portal business packages to work; these aliases are listed in the following table:

System	Alias	For Bus Pack
ECC	SAP_R3_HumanResources	ESS / MSS
Web Dynpro runtime (ECC)	SAP_WebDynpro_XSS	ESS / MSS
SRM	SAP_EBP, SAP_R3_Procurement	SRM / Supplier Collaboration

It is also important to note that system aliases cannot be transported - they must be assigned manually in each EP environment.

15. Click the **Save** button.

This completes the modifications to the SAP configuration. For more information, consult the SAP documentation. Continue with the following section for configuring the BIG-IP system.

Preparation Worksheet

In order to use the iApp for SAP Enterprise Portal, you need to gather some information, such as SAP server IP addresses and domain information. Use the following worksheet to gather the information you will need while running the template. The worksheet does not contain every question in the template, but rather includes the information that is helpful to have in advance. More information on specific template questions can be found on the individual pages.

You might find it useful to print this table and then enter the information.

🔄 **Note:** Although we show space for 7 pool members, you may have more or fewer members in each pool.

IP Addresses/FQDN	SSL Offload	Pool Members	Sync/Failover Groups*	TCP request queuing*	WAN or LAN clients
IP address for the SAP Portal LTM virtual server: FQDN that will resolve to the virtual server address:	<i>Offloading SSL?</i> Yes No If offloading SSL, import a certificate and key into the BIG-IP LTM before running the template. Certificate: Key:	SAP Portal IP addresses: 1: 2: 3: 4: 5: 6: 7: Port used by SAP Portal:	If using the Advanced feature of Sync/Failover Groups, you must already have a Device Group and a Traffic Group Device Group name: Traffic Group name:	If using TCP request queuing, you should know the queue length and timeout, as well as the connection limit for the node. Request queue length: Timeout: Node Connection limit:	Most clients connecting through BIG-IP to SAP Portal are coming over a: LAN WAN
Optional Modules (you must have provisioned modules before running the template)					
<i>Application Visibility Reporting (AVR)*</i>		<i>WebAccelerator*</i>	<i>Application Security Manager (ASM)*</i>		
If using AVR, we strongly recommend you first create a custom Analytics profile before running the template. Analytics profile name:		All FQDNs for SAP Portal: 1: 2: 3:	Language encoding the application uses (the default is Unicode (utf-8)):		

* *Optional*

Configuring the BIG-IP iApp for SAP Enterprise Portal

Use the following guidance to help you configure the BIG-IP system for SAP Enterprise Portal using the BIG-IP iApp template.

Getting Started with the iApp for SAP Enterprise Portal

To begin the SAP iApp Template, use the following procedure.

1. Log on to the BIG-IP system.
2. On the Main tab, expand **iApp**, and then click **Application Services**.
3. Click **Create**. The Template Selection page opens.
4. In the **Name** box, type a name. In our example, we use **SAP-Portal_**.
5. From the **Template** list, select **f5.sap_enterprise_portal**.
The SAP Enterprise Portal template opens.

Advanced options

If you select **Advanced** from the **Template Selection** list, you see Sync and Failover options for the application. This feature, new to v11, is a part of the Device Management configuration. If you enable sync and failover, you can select a device group that synchronizes BIG-IP configuration data among devices and a traffic group of related objects that fail over to another device if the current device becomes unavailable.

Important

If you plan on using Device and Traffic Groups with the iApp for SAP Enterprise Portal, you must have configured the Device Group and Traffic Group before beginning the iApp. For more information on Device Management, see the Online help or product documentation.

1. Configure Device and Traffic Groups?

If you want to configure the Application for Device and Traffic groups, select **Advanced** from the **Template Selection** list.

a. Device Group

If you select Advanced from the list, the Device Group and Traffic Group options appear. If necessary, uncheck the Device Group box and then select the appropriate Device Group from the list.

b. Traffic Group

If necessary, uncheck the Traffic Group box and then select the appropriate Traffic Group from the list.

Analytics

This section of the template asks questions about Analytics. The Application Visibility Reporting (AVR) module allows you to view statistics specific to your SAP Enterprise Portal implementation. AVR is available on all BIG-IP systems v11 and later, however you must have the AVR provisioned for this option to appear. Note that these are only for application visibility reporting, you can view object-level statistics from the BIG-IP without provisioning AVR.

If you plan on using AVR for analytics, we recommend creating a custom Analytics profile before beginning the template. To create a new profile, from the Main tab, select profiles and then click Analytics. Click New and then configure the profile as applicable for your configuration. See the online help or product documentation for specific instructions.

Tip

If using AVR, create a new Analytics profile before beginning the iApp for more specific reporting

1. **Enable Analytics**

Choose whether you want to enable AVR for Analytics.

2. **Analytics Profile**

You must decide whether to use the default Analytics profile, or create a new one. As mentioned previously, we recommend creating a new profile to get the most flexibility and functionality out of AVR. If you choose to create a new profile after starting the template, you must exit the template, create the profile, and then restart the template.

To use the default Analytics profile, choose Use **Default Profile** from the list.

To choose a custom profile, leave the list set to **Select a Custom Profile**, and then from the Analytics profile list, select the custom profile you created.

Virtual Server Questions

The next section of the template asks questions about the BIG-IP virtual server. A virtual server is a traffic-management object on the BIG-IP system that is represented by an IP address and a service. Clients can send application traffic to a virtual server, which then directs the traffic according to your configuration instructions.

1. **IP address for the virtual server**

This is the address clients use to access SAP Enterprise Portal (or a FQDN will resolve to this address).

2. **Routes or secure network address translation**

If the SAP Portal servers do not have a route back for clients through the BIG-IP, (i.e. if they do not use the BIG-IP as the default gateway), the BIG-IP uses Secure Network Address Translation (SNAT) Automap (one exception, see #3) to translate the client's source address to an address configured on the BIG-IP.

If you indicate that the SAP Portal servers do have a route back to the clients through the BIG-IP, the BIG-IP does not translate the client's source address; in this case, you must make sure that the BIG-IP is configured as the gateway to the client networks (usually the default gateway) on the Portal servers.

We recommend choosing **No** from the list because it does not require you to configure routing manually.

If you are configuring your BIG-IP LTM in a "one-armed" configuration with your SAP Portal servers -- where the BIG-IP virtual server(s) and the Portal server have IP addresses on the same subnet -- you must choose No.

If you do select Yes from the list, the following question about 64,000 connections does not appear.

3. **More than 64,000 simultaneous connections**

If you do not expect more than 64,000 simultaneous connections, leave this answer set to **No** and continue with #4.

If you have a large deployment and expect more than 64,000 connections at one time, the iApp creates a SNAT Pool instead of using SNAT Automap. With a SNAT Pool, you need one IP address for each 64,000 connections you expect. Select **Yes** from the list. A new row appears with an IP address field. In the **Address** box, type an IP address and then click **Add**. Repeat for any additional IP addresses.

4. **NTLM**

If you have configured the SAP Enterprise Portal servers to use NTLM authentication, select Yes from the list. If the Enterprise Portal servers do not use NTLM, leave the list set to No.

SSL Encryption questions

Before running the template you should have already imported a certificate and key onto the BIG-IP system. While the BIG-IP system does include a self-signed SSL certificate that can be used internally or for testing, we strongly recommend importing a certificate and key issued from a trusted Certificate Authority.

For information on SSL certificates on the BIG-IP system, see the online help or the *Managing SSL Certificates for Local Traffic* chapter in the **Configuration Guide for BIG-IP Local Traffic Manager** available at <http://support.f5.com/kb/en-us.html>.

To configure the BIG-IP to offload SSL, select **Yes** from the list.

1. **Certificate**
Select the certificate for you imported for Enterprise Portal from the certificate list.
2. **Key**
Select the associated key from the list.

Server Pool, Load Balancing, and Service Monitor questions

In this section, you add the Enterprise Portal servers, and configure the health monitor and pool.

1. **New Pool**
Choose **Create New Pool** unless you have already made a pool on the LTM for the Enterprise Portal devices.
2. **Load balancing method**
While you can choose any of the load balancing methods from the list, we recommend the default, **Least Connections (member)**.
3. **Address/Port**
Type the IP Address and Port for each Enterprise Portal server (the default port for SAP Portal is 50000). You can optionally add a Connection Limit (see note on the left). Click **Add** to add additional servers to the pool.
4. **TCP Request Queuing**
TCP request queuing provides the ability to queue connection requests that exceed the capacity of connections for a pool as determined by the connection limit. Consequently, instead of dropping connection requests that exceed the capacity of a pool, TCP request queuing enables those connection requests to reside within a queue in accordance with defined conditions until capacity becomes available. For more information on TCP Request Queuing, see the *New Features Guide for BIG-IP Version 11*, available on Ask F5.

If you want the BIG-IP to queue TCP requests, select **Yes** from the list. Additional options appear.
 - a. Type a queue length in the box. Leave the default of 0 for unlimited.
 - b. Type a number of milliseconds for the timeout value.
5. **Health Monitor**
Choose **Create New Monitor** unless you have already made a health monitor on the LTM for the Enterprise Portal devices.
6. **Interval**
Specifies how often the system checks the health of the servers. We recommend the default of 30 seconds.

↪ Important

If you enable TCP Request Queuing, you must have a Connection Limit set on at least one of the nodes when configuring the Address/Port

7. **HTTP Request**
This is optional. You can configure the template to retrieve a specific page by typing the path here. Leaving the default (GET /) marks the node up if anything is returned from the web page.
8. **HTTP 1.1 FQDN**
This question asks for the FQDN the clients use to access Enterprise Portal for use in the health monitor. Type it here.
9. **Monitor response string**
Optional. If you configured a unique HTTP Request, this is where you enter the expected response.

Protocol Optimization and Security Questions

In this section, you configure security and protocol optimizations.

1. **WAN or LAN**
Specify whether most clients are connecting over a WAN or LAN. Because most Enterprise Portal clients are likely to be coming over the WAN, we recommend selecting WAN (the default).
2. **WebAccelerator**
If you have licensed and provisioned the WebAccelerator module, you have the option of using it for SAP Enterprise Portal. The WebAccelerator provides application acceleration for remote users.
 - a. *DNS names*
If you select Yes, an additional row appears in the template asking for the fully qualified domain names used for SAP Enterprise Portal. The BIG-IP system uses these entries for the Requested Hosts field, allowing the WebAccelerator module to accelerate the traffic to these virtual hosts.

In the **Host** box, type the **FQDN**. If you have additional FQDNs, click the **Add** button.
 - b. *X-WA-info Header*
By default, the WebAccelerator X-WA-info header is not included in the response from the BIG-IP. This header is useful for debugging WebAccelerator behavior. There are two additional options:
 - Standard: If you choose Standard, the BIG-IP inserts a HTTP header that includes numeric codes which indicate if and how each object was cached.
 - Debug: If you choose Debug, the BIG-IP includes extended information which may help for extended troubleshooting.
 - c. *WebAccelerator Performance monitor*
While the BIG-IP Dashboard provides statistics and performance graphs related to WebAccelerator, you can choose to enable the WebAccelerator performance monitor for legacy WebAccelerator performance monitoring for debugging purposes. The results can be found in the Main tab of the navigation page, under WebAccelerator, by clicking Traffic Reports.
In our example, we leave the performance monitor **Disabled**.
 - d. *WebAccelerator policy*
For this template, F5 recommends the **SAP Portal** policy to achieve the best results for Web acceleration of SAP traffic. Should F5 publish an updated policy to DevCentral that

you have downloaded and imported, or if a custom policy is created for your environment (locally), you can select that custom policy from the list. In our example, we leave the default, **SAP Portal**.

3. Application Security Manager

If you have licensed and provisioned the Application Security Manager (ASM), you have the option of using it to protect SAP Enterprise Portal. The ASM module is an advanced web application firewall that significantly reduces and mitigates the risk of loss or damage to data, intellectual property, and web applications.

Important

If you choose to use ASM, the iApp template sets the policy enforcement mode to transparent. In this mode, violations are logged but not blocked. Before changing the mode to blocking, review the log results and adjust the policy for your deployment if necessary.

- a. If you select Yes, an additional row appears asking for the language encoding. Select the proper language from the list.

Finished

Review your answers to the questions. When you are satisfied, click the **Finished** button. The BIG-IP system creates the relevant objects.

Next steps

After completing the iApp Template, the BIG-IP Application Services page opens for the SAP Enterprise Portal service you just created. To see the list of all the configuration objects created to support SAP Enterprise Portal, on the Menu bar, click **Components**. The complete list of all SAP Enterprise Portal related objects opens. You can click individual objects to see the settings. Once the objects have been created, you are ready to use the new deployment.

Modifying DNS settings to use the BIG-IP virtual server address

Before sending traffic to the BIG-IP system, your DNS administrator may need to modify any DNS entries for the SAP Enterprise Portal implementation to point to the BIG-IP system's virtual server address.

Modifying the iApp configuration

The iApp application service you just created can be quickly and easily modified if you find it necessary to make changes to the configuration. The Strict Updates feature of the iApp prevents users from manually modifying the iApp configuration (Strict Updates can be turned off, but use extreme caution). As a safer option, the iApp allows you to re-enter the template, make changes, and then update the template. The modifications are automatically made to any of the associated objects.

To modify the configuration

1. On the Main tab, expand **iApp** and then click **Application Services**.
2. Click the name of your SAP Enterprise Portal Application service from the list.
3. On the Menu bar, click **Reconfigure**.
4. Make the necessary modifications to the template.
5. Click the **Finished** button.

Viewing statistics

You can easily view a number of different statistics on the BIG-IP system related to the SAP Enterprise Portal configuration objects created by the iApp template. You can get statistics specific to the Application Service if you have provisioned AVR. Otherwise, you can always get object-level statistics.

AVR statistics

If you have provisioned AVR, you can get application-level statistics for your SAP Enterprise Portal application service.

To view AVR statistics

1. On the Main tab, expand **iApp** and then click **Application Services**.
2. From the Application Service List, click the SAP Enterprise Portal service you just created.
3. On the Menu bar, click **Analytics**.
4. Use the tabs and the Menu bar to view different statistics for your SAP Enterprise Portal iApp.

Object-level statistics

If you haven't provisioned AVR, or want to view object-level statistics, use the following procedure.

To view object-level statics

1. On the Main tab, expand **Overview**, and then click **Statistics**.
2. From the **Statistics Type** menu, you can select **Virtual Servers** to see statistics related to the virtual servers.
3. You can also choose **Pools** or **Nodes** to get a closer look at the traffic.
4. To see Networking statistics in a graphical format, click **Dashboard**.

For more information on viewing statistics on the BIG-IP system, see the online help or product documentation.

Appendix: Manual configuration table

We strongly recommend using the iApp template to configure the BIG-IP LTM for SAP Enterprise Portal. Advanced users extremely familiar with the BIG-IP system can use the following table to manually configure the BIG-IP system.

The following table contains a list of BIG-IP LTM configuration objects along with any non-default settings you should configure as a part of this deployment. Unless otherwise specified, settings not mentioned in the table can be configured as applicable for your configuration. For specific instructions on configuring individual objects, see the online help or product manuals.

BIG-IP LTM Object	Non-default settings/Notes		
Health Monitor (Main tab-->Local Traffic -->Monitors)	Name	Type a unique name	
	Type	HTTP	
	Interval	30 (recommended)	
	Timeout	91 (recommended)	
Pool (Main tab-->Local Traffic -->Pools)	Name	Type a unique name	
	Health Monitor	Select the monitor you created above	
	Slow Ramp Time¹	300	
	Load Balancing Method	Choose a load balancing method. We recommend Least Connections (Member)	
	Address	Type the IP Address of the SAP Enterprise Portal nodes	
	Service Port	50000 (click Add to repeat Address and Service Port for all nodes)	
Profiles (Main tab-->Local Traffic -->Profiles)	HTTP (Profiles-->Services)	Name Parent Profile Rewrite Redirect ²	Type a unique name http Matching
	TCP WAN (Profiles-->Protocol)	Name Parent Profile	Type a unique name tcp-wan-optimized
	TCP LAN (Profiles-->Protocol)	Name Parent Profile	Type a unique name tcp-lan-optimized
	Persistence (Profiles-->Persistence)	Name Persistence Type	Type a unique name Cookie
	OneConnect (Profiles-->Other)	Name Parent Profile	Type a unique name oneconnect
	Client SSL² (Profiles-->SSL)	Name Parent Profile Certificate and Key	Type a unique name clientssl Select the Certificate and Key you imported from the associated list
	Web Acceleration (Profiles-->Services)	Name Parent Profile	Type a unique name optimized-caching
	HTTP Compression (Profiles-->Services)	Name Parent Profile Content List -->Include List (Add each entry to the Content Type box and then click Include)	Type a unique name wan-optimized-compression application/vnd.ms-publisher application/(xls excel msexcel ms-excel x-excel x-xls xmsexcel x-ms-excel vnd.excel vnd.msexcel vnd.ms-excel) application/(word doc msword winword ms-word x-word x-msword vnd.word vnd.msword vnd.ms-word) application/(xml x-javascript javascript x-ecmascript ecmascript) application/(powerpoint mspoverpoint ms-powerpoint x-powerpoint x-mspowerpoint vnd.powerpoint vnd.mspowerpoint vnd.ms-powerpoint vnd.ms-pps) application/(mpp msproject x-msproject x-ms-project vnd.ms-project) application/(visio x-visio vnd.visio vsd x-vsd x-vsd) application/(pdf x-pdf acrobat vnd.pdf)

¹ You must select **Advanced** from the **Configuration** list for these options to appear

² Only required if offloading SSL on the BIG-IP LTM

Configuration table, continued

BIG-IP LTM Object	Non-default settings/Notes	
Virtual Servers (Main tab-->Local Traffic -->Virtual Servers)	HTTP	
	Name	Type a unique name.
	Address	Type the IP Address for the virtual server
	Service Port	80
	Protocol Profile (client)^{1,2}	Select the WAN optimized TCP profile you created above
	Protocol Profile (server)^{1,2}	Select the LAN optimized TCP profile you created above
	HTTP Profile²	Select the HTTP profile you created above
	Web Acceleration profile²	Select the Web Acceleration profile you created above
	HTTP Compression profile²	Select the HTTP Compression profile you created above
	OneConnect²	Select the OneConnect profile you created above
	SNAT Pool³	Automap (optional; see footnote ³)
	Default Pool²	Select the pool you created above
	Persistence Profile²	Select the Persistence profile you created
	iRule⁴	If offloading SSL only: Enable the built-in _sys_https_redirect irule
	HTTPS⁵	
	Name	Type a unique name.
	Address	Type the IP Address for the virtual server
	Service Port	443
	Protocol Profile (client)¹	Select the WAN optimized TCP profile you created above
	Protocol Profile (server)¹	Select the LAN optimized TCP profile you created above
	HTTP Profile	Select the HTTP profile you created above
	Web Acceleration profile	Select the Web Acceleration profile you created above
	HTTP Compression profile	Select the HTTP Compression profile you created above
OneConnect	Select the OneConnect profile you created above	
SSL Profile (client)	Select the Client SSL profile you created above	
SNAT Pool²	Automap (optional; see footnote ³)	
Default Pool	Select the pool you created above	
Persistence Profile	Select the Persistence profile you created	

¹ You must select **Advanced** from the **Configuration** list for these options to appear

² Do not enable these objects on the HTTP virtual server if offloading SSL. The HTTP virtual server is only used for redirecting users to the HTTPS virtual server, and only requires a name, IP address, Port, and the redirect iRule.

³ If want to use SNAT, and you have a large SAP deployment expecting more than 64,000 simultaneous connections, you must configure a SNAT Pool with an IP address for each 64,000 simultaneous connections you expect. See the BIG-IP documentation on configuring SNAT Pools.

⁴ Only enable this iRule if offloading SSL

⁵ Only create this virtual server if offloading SSL

Document Revision History

Version	Description
1.0	New Version

F5 Networks, Inc. 401 Elliott Avenue West, Seattle, WA 98119 888-882-4447 www.f5.com

**F5 Networks,
Corporate Headquarters**
info@f5.com

**F5 Networks
Asia-Pacific**
apacinfo@f5.com

**F5 Networks Ltd.
Europe/Middle-East/Africa**
emeainfo@f5.com

**F5 Networks
Japan K.K.**
f5j-info@f5.com

